

PERIMETER
SURVEYING & MAPPING
 Certificate of Authorization No. LB7264
 Prepared by: Jeff S. Hodapp, P.S.M.
 947 Clint Moore Road
 Boca Raton, Florida 33487
 Tel: (561) 241-9988
 Fax: (561) 241-5182

REYES PLAT

A REPLAT OF LOTS 11, 12, 17 AND 18, "BLOCK 32 DELRAY", (P.B. 6, PG. 97, P.B.C.R.)
 IN SECTION 17, TOWNSHIP 46 SOUTH, RANGE 43 EAST, CITY OF DELRAY BEACH,
 PALM BEACH COUNTY, FLORIDA.

161

SHEET 2 OF 2

BLOCK 24
 "MAP OF THE TOWN OF LINTON"
 (P.B. 1, PG. 3, P.B.C.R.)



- ABBREVIATIONS:**
- CONC. = CONCRETE
 - COR. = CORNER
 - D = DELTA (CENTRAL ANGLE)
 - D.E. = DRAINAGE EASEMENT
 - DIA. = DIAMETER
 - F.P.L. = FLORIDA POWER AND LIGHT
 - G.U.E. = GENERAL UTILITY EASEMENT
 - I.R. = IRON ROD
 - I.R.C. = IRON ROD & CAP
 - L = ARC LENGTH
 - L.B. = LICENSED BUSINESS
 - L.S. = LICENSED SURVEYOR
 - MON. = MONUMENT
 - N.R. = NON-RADIAL
 - O.R.B. = OFFICIAL RECORDS BOOK
 - O/S = OFFSET
 - P.A.E. = PUBLIC ACCESS EASEMENT
 - P.B.C.R. = PALM BEACH COUNTY RECORDS
 - P.B. = PLAT BOOK
 - P.G. = PAGE
 - P.C.P. = PERMANENT CONTROL POINT
 - P.O.B. = POINT OF BEGINNING
 - P.O.C. = POINT OF COMMENCEMENT
 - P.R.M. = PERMANENT REFERENCE MONUMENT
 - P.S.M. = PROFESSIONAL SURVEYOR & MAPPER
 - R = RADIUS
 - R/W = RIGHT-OF-WAY
 - S.E. = SEWER EASEMENT
 - SEC. = SECTION
 - S.A. = SQUARE FEET
 - U.E. = UTILITY EASEMENT
 - W.E. = WATER EASEMENT

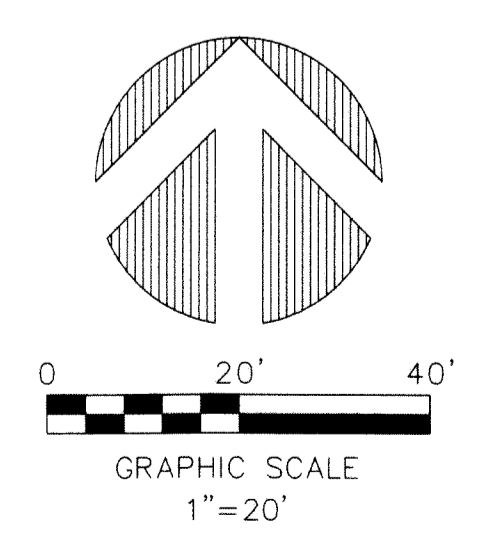

- LEGEND**
- ⊙ = CENTERLINE
 - ⊙ = PRM - SET PERMANENT REFERENCED MONUMENT LB#7264. 4"x4" CONCRETE MONUMENT WITH / ALUMINUM DISC STAMPED "PRM LB 7264.

